

# BROYEUR DE VERRE

Spé. MAGNUM

## Caractéristiques techniques :

<b>Bouteilles par heure</b>	<b>500</b>
<b>Electricité</b>	<b>400V / 50 Hz</b>
<b>Poids</b>	<b>140 kg</b>
<b>Puissance moteur</b>	<b>2 kW</b>
<b>Cage pour conteneur</b>	<b>120L maximum</b>
<b>Ouverture de chargement</b>	<b>150 x 150 mm</b>
<b>Hauteur de chargement</b>	<b>1725 mm</b>



## Dimensions

## Option possible : Insonorisation

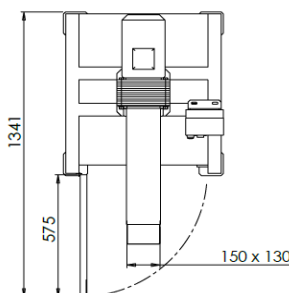
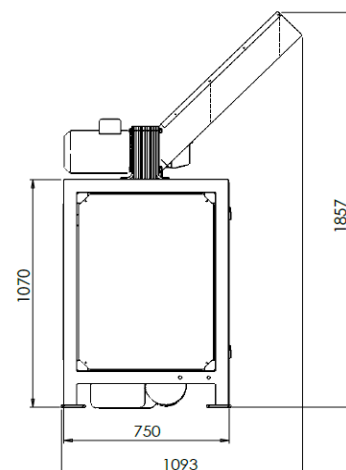
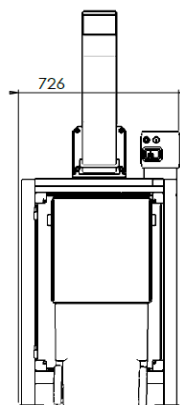

## Conformité CE :

Les matériels ECP Group sont équipés des sécurités électriques et conçus dimensionnellement pour être conformes A la législation du travail et aux normes CE



Rue du Progrès – Zone d'activités de la Croix Danet – BP 7 – 44140 GENESTON (FRANCE)

Téléphone 00 33 (0) 240 261 316 – Télécopie 00 33 (0) 240 261 298

[www.ecp-group.com](http://www.ecp-group.com) - E-mail : [commercial@ecp-group.com](mailto:commercial@ecp-group.com)

S .A.R.L. au capital de 320 000 € - N° d'identification 326 615 762 – RCS Nantes Code NAF 285 D – TVA intracom. FR 52 326 615 762